

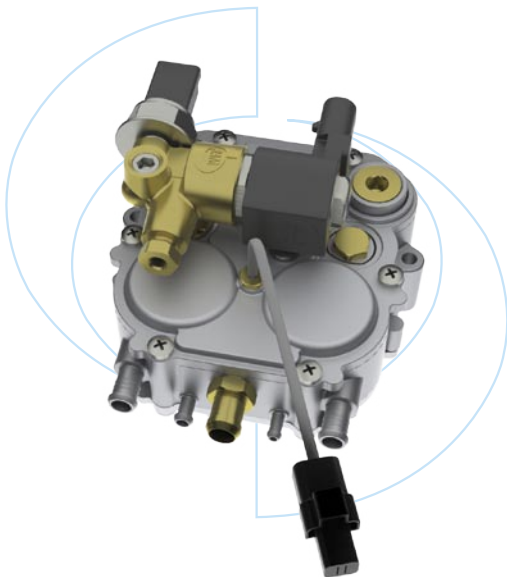

XENON 04C STD



 **XENON regulators are easy to install, due to the fact that gas, air and water connections are in the same direction and close each other.**

The servo-circuit allows the best outlet pressure stability, at different pressures in tank.

The Xenon 04C is equipped with a brass body at reducer inlet, where it is installed a solenoid valve and an electronic pressure sensor. This sensor allows a continuous indication of gas level in the tank (not at steps).

 I riduttori della famiglia XENON sono di facile installazione, data la vicinanza e lo stesso orientamento delle varie connessioni acqua, gas e aria.

Il sistema servo consente una grande stabilità della pressione in uscita al variare della pressione di bombola.

Lo Xenon 04C è dotato di un gruppo elettrovalvola con sensore elettronico di pressione in ingresso riduttore. Il sensore permette un'indicazione continua del livello di gas in bombola (non a step).

 Die Druckminderer der Familie XENON sind aufgrund der Nähe und der Ausrichtung der verschiedenen Wasser, Gas- und Luftanschlüsse ausgesprochen installationsfreundlich.

Das Servosystem bietet auch bei Druckschwankungen in der Flasche große Ausgangsdruckstabilität.

Xenon 04C ist beim Druckminderereingang mit einer Magnetventilgruppe mit einem elektronischen Drucksensor ausgestattet. Der Sensor ermöglicht die stufenlose Anzeige des Gasstands in der Flasche (also keine stufenweise).

 Los reductores de familia XENON son de fácil instalación, dada la proximidad y la misma orientación de las distintas conexiones agua, gas y aire. El sistema de compensación permite una gran estabilidad de la presión a la salida al variar la presión del tanque.

El Xenón 04C está dotado de un grupo electrovalvula con un sensor electrónico de presión de entrada reductor. El sensor permite una indicación continua del nivel de gas en el tanque.

Technical specifications

Type of gas Tipo di gas Gastyp Tipo de gas	CNG
Engine maximum power Potenza massima motore Für Motoren mit Leistungen bis zu Para motores con potencia hasta	100 kW
Gas outlet pressure Pressione gas in uscita Ausgangsdruck Presión de salida	2,0 bar
Gas inlet Ingresso gas Eingang gaz Entrada gas	Female connection with ferrule for \varnothing 6 mm pipe Connessione femmina con ogiva per tubo \varnothing 6 mm Rohranschluss mit Innengewinde und Ogive \varnothing 6 mm Conexión hembra con virola para tubo \varnothing 6 mm
Gas outlet Uscita gas Ausgang gaz Salida gas	Male connection for rubber hose \varnothing_{int} 12 mm Connessione maschio per tubo in gomma \varnothing 12 mm Steckanschluss für Gummischlauch \varnothing 12 mm Conexión macho para tubo de goma \varnothing 12 mm
Engine cooling liquid Inlet/Outlet Ingresso/uscita liquido di raffreddamento Ein-/Ausgang Kühlfüssigkeit Entrada/salida líquido de refrigeración	Male connection for rubber hose \varnothing_{int} 10 mm Connessione maschio per tubo in gomma \varnothing 10 mm Steckanschluss für Gummischlauch \varnothing 10 mm Conexión macho para tubo de goma \varnothing 10 mm
Pressure sensor Sensore di pressione Drucksensor Sensor de presión	High precision electronic sensor (0-260 bar) Sensore di pressione elettronico (0-260 bar) Elektronischer Drucksensor (0-260 bar) Sensor de presión electrónico (0-260 bar)
Cut off automatic valve Elettrovalvola Magnetventil Electrovalvula	Present (Red. inlet) - IP 54 electrical connection Presente (Ingresso rid.) - Connessione elettrica IP54 Gegeben (Eingang reg.) - Stromanschluss IP54 Presente (Entrada red.) - Conexión eléctrica IP54
Solenoid valve nominal voltage Tensione nominale elettrovalvola Nennspannung Magnetventil Tensión nominal electrovalvula	12 V d.c.
Solenoid valve nominal power Potenza nominale elettrovalvola Nennleistung Magnetventil Potencia nominal electrovalvula	13 W (12 V)
Manifold pressure nozzle Presa di pressione collettore Anschluss für Kollektorkompensation Enlace para compensación al colector	Present (integrated) Presente (integrata) Gegeben (eingebaut) Presente (integrada)
Reducer temperature sensor Sensore di temperatura riduttore Temperaturfühler Druckminderer Sensor de temperatura regulador	Optional Opzionale Sonderzubehör Opcional
Pressure relief valve Valvola di sicurezza Sicherheitsventil Válvula de seguridad	Present (integrated) Presente (integrata) Gegeben (eingebaut) Presente (integrada)
Gas pressure reduction stages Stadi di riduzione di pressione gas Reduzierstufen Etapas de reducción	2 + servo-circuit 2 + Circuito servo 2 + Servosystem 2 + Sistema de compensación
Operating temperature Temperatura di funzionamento Betriebstemperatur Temperatura de funcionamiento	- 40° / +120°C
Overall dimensions Dimensioni d'ingombro Äußere Abmessungen Dimensiones	129 x 142 x 88 mm
Homologations Omologazioni Zulassungen Homologaciones	R110-00 and ISO15500 (under test) R110-00 e ISO15500 (in fase di test) R110-00 und ISO15500 (under test) R110-00 y ISO15500 (En fase de prueba)



RAM Regulators srl

Via Col. A. Varisco, 12 - 35010 Vigonza (PD) - ITALY

tel. +39 049 6226456 - fax +39 049 8953685 - www.ramregulators.com - info@ramregulators.com - P.Iva e C.F. 04200220269

XENON 04C STD

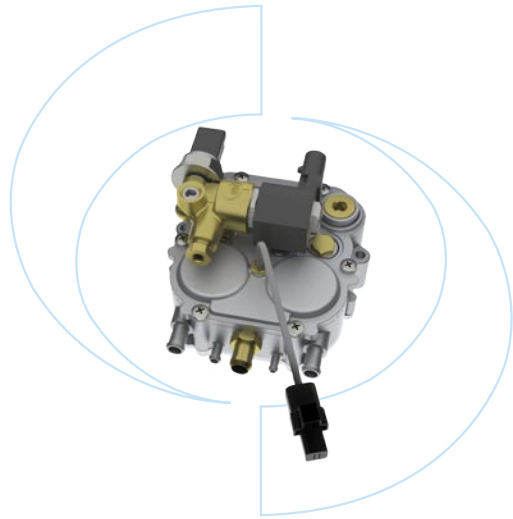

Technical design and dimensions

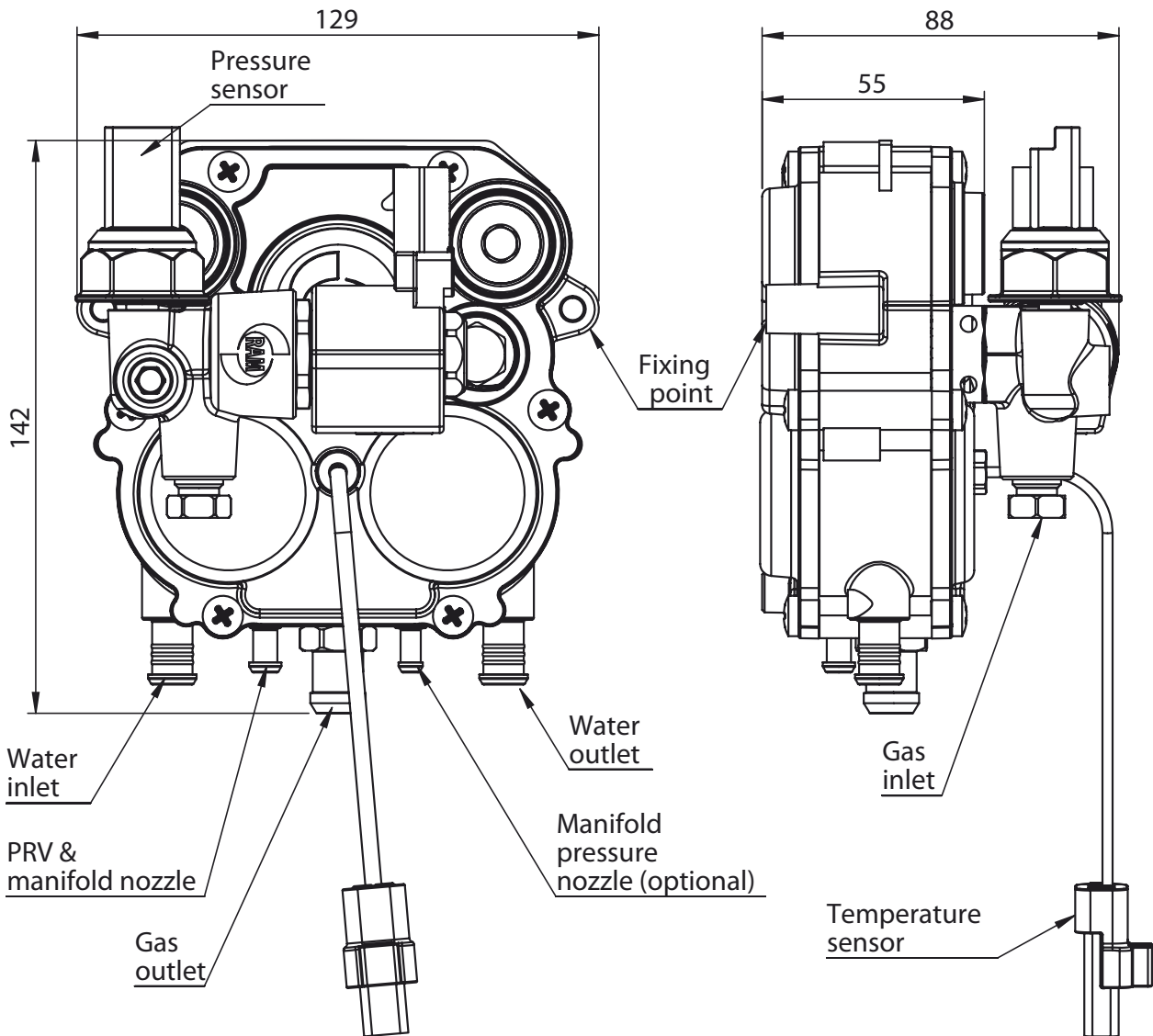

RAM Regulators srl

Via Col. A. Varisco, 12 - 35010 Vigonza (PD) - ITALY

tel. +39 049 6226456 - fax +39 049 8953685 - www.ramregulators.com - info@ramregulators.com - P.Iva e C.F. 04200220269